

CBHXS/9-90° Half Expansion Clamp

Type No.	Catalogue No	Busbar Ⓜ	Stud Ⓢ	A	B	Unit Weight
CBHXS/9-25	C27383	25	To Suit	To Suit	64	Varies
CBHXS/9-38	C27393	38	To Suit	To Suit	64	Varies
CBHXS/9-50	C27403	50	To Suit	To Suit	64	Varies
CBHXS/9-64	C27413	64	To Suit	To Suit	76	Varies
CBHXS/9-76	C27423	76	To Suit	To Suit	76	Varies

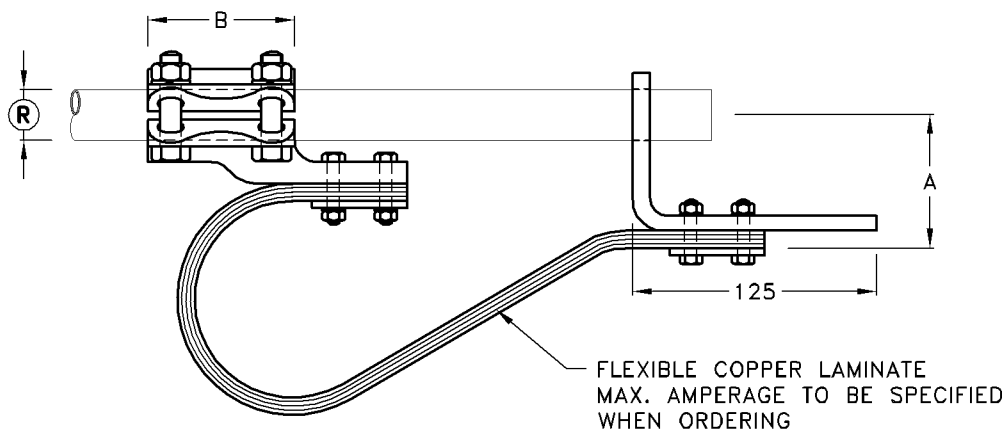

CBHXP-Pad Half Expansion Clamp

Type No.	Catalogue No	Busbar Ⓜ	A	B	Unit Weight
CBHXP-25	C27303	25	To Suit	64	Varies
CBHXP-38	C27313	38	To Suit	64	Varies
CBHXP-50	C27323	50	To Suit	64	Varies
CBHXP-64	C27333	64	To Suit	76	Varies
CBHXP-76	C27343	76	To Suit	76	Varies

- Note:**
- 1) Busbar contact surface areas are smooth bore.
 - 2) Current rating to be specified when ordering. 1250A; 1600A; 2500A.
 - 3) Material: GM3, hot tin dipped.
: Bolts & Nuts-Steel HT.8.8 H.D.G.
 - 4) Voltage: 150kV Max.